

# 5R 7R BEAM MOVE HEAD LIGHT **USER MANUAL**

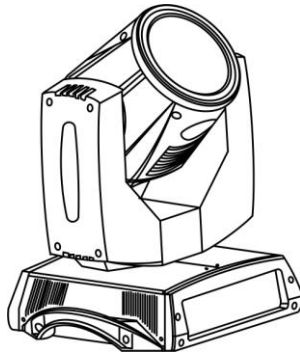

Please read over this manual before operation the light

## Chapter 1 Installation and attention

### 1. Maintenance

To reduce the risk of electrical shock or fire, do not expose this unit to rain or moisture.

Intermittently using will extend this item's service life.

Please clear the fan ,fan net , and optical lens in order to keep good work state.

Do not use the alcohol or any other organic solvent to wipe the shell.

### 2. Statement

The product has perfect performance and integrity packing. All users should be strictly complying with the warning and operating instructions as stated. Or we aren't in charge of any result by

misusing. Any damage resulting by misuse is not within the Company's warranty.

Any fault or

problem caused by neglecting the manual is also not in the charge of dealers.

**Note:** All information is subject to change without prior notice.

### 3. Safety Precaution

In order to guarantee the product's life, please don't put it in the damp places or even the environment over 60degrees.

Always mount this unit in safe and stable matter.

Install or dismantle should operate by professional engineer.

Using lamp, the change rate of power voltage should be within $\pm 10\%$ . If the voltage is too high, it will shorten the light's life; If it's not enough, will influence the effect.

Please restart it 20 minutes later after turning off light , until full-cooling. Frequent switching will reduce the life span of lamps and bulbs; intermittent using will improve the life of bulbs and lamps.

In order to make sure the product is used well, please read the Manual carefully.

### 4. Product Instruction

lamp: Philips MSD Platinum 5R or YODN 5R (life:2200 hours Color temperature: 8000K)

Channel mode:20 DMX512 Channel

Pan scan:540°(16bit) Electric correction

Tilt scan:270° (16bit) Electric correction

Amazing dot matix, four tact switch, 180° turning show

Color wheel: one color wheel, 14 kinds of color chips in one color wheel

Gobo: 17 gobos

Effect Wheel: Rotation eight prism, effect move , frost

0-100% mechanical dimming, mechanical dimming and free dimming available. strobe macro control available.

Lens optical system achanical fouce .beam angle 0~4°

Over heat protection

Power Input: 100-240V ,50/60Hz

Power Dissipation:350W

IP level :IP20  
 Magnetic ballast and AC/Dc power supply  
 Product Size: 523x337x511mm  
 Packing Size: 635X440X725  
 Net weight: 19.5KG

**5. Cable connection (DMX)**

Use a cable conforming to specifications EIA RS-485: 2-pole twisted, shielded, 120Ohm characteristic impedance, 22-24 AWG, low capacity. Do not use microphone cable or other cable with characteristics differing from those specified. The end connections must be made using XLR type 3 or 5-pin male/female connectors. A terminating plug must be inserted into the last projector with a resistance of 120Ohm (minimum 1/4 W) between terminals 2 and 3.

**IMPORTANT:** The wires must not make contact with each other or with the metal casing of the connectors.  
 The casing itself must be connected to the shield braid and to pin 1 of the connectors.

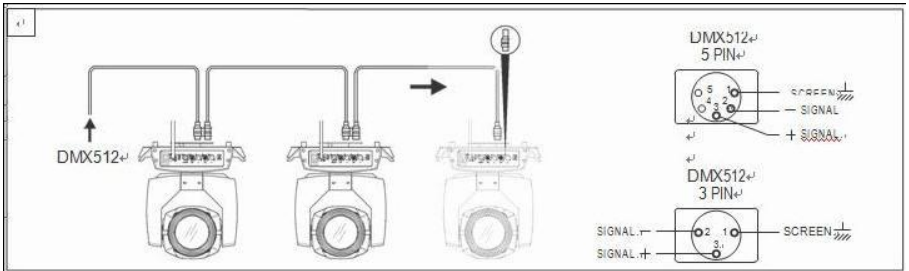

Figure 1 DMX Cable connection

**6. Rigging (Optional)**

This equipment can be positioned and fixed by clamp in every direction of the stage. Locking system makes it easy to fasten to the bracket.

Attention! Two clamps is needed to fix the equipment. Every clamp is locked by fastener of 1/4 kind. Fastener can only be locked clockwise.

Attention! Fasten a safety string to the additional hole of side aluminum piece. The secondary accessory can not hang on the delivery handle. Nip the equipment on bracket.

Check if rigging clamp (not including the one inside) damaged or not? If stand ten times weight as the equipment. Make sure the architecture can stand ten times weight as all the equipments, clamps, wirings and other additional fixtures.

Screws for clamping must be fixed firmly. Take one M12 screw (Grade 8.8 or higher) to clamp bracket, and then screw the nuts.

Level the two hanging points at the bottom of clamp. Insert fastener to the bottom, lock the two levers by 1/4 rotating clockwise; then install another clamp.

Install on safety string which stands at least ten times weight as equipment. Terminal of the accessory is designed for clamps.

Make sure pan/tilt lock unlocked or not. Keep the distance more than 1M from equipment to flammable material or lighting source.

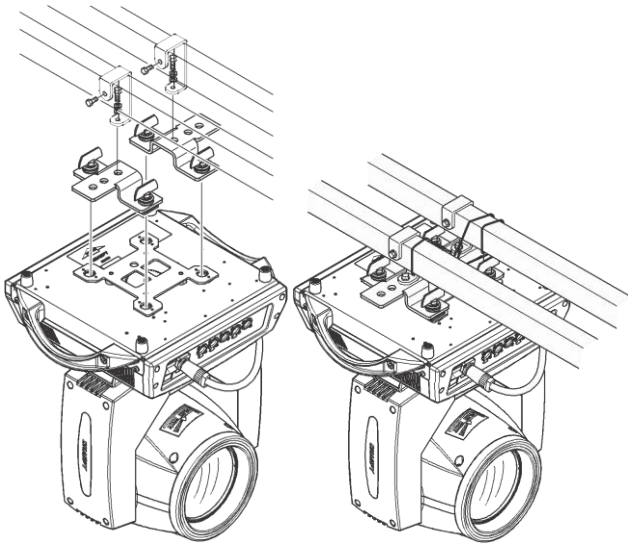

Figure 2 Installation

## Chapter 2 Panel operation

### 1. Operation

#### 1. Operate light with touch or encoder button

The left area is TFT Displayer and touch, click item or value with finger will to complete operation of set light setting(parameters) or view light state.

The area on the right hand side is rotary encoder with button, As auxiliary input interface, if disable touch function,, the encoder can be choose to set or view the item, and then press the encoder button to confirm the selection, rotary encoder again set the parameter value, finally, Press encoder button one again to save value or setting.

#### 2. Parameter value setting

When the selected item is value need to been modified, the dialog shown in Figure 4 will popup.

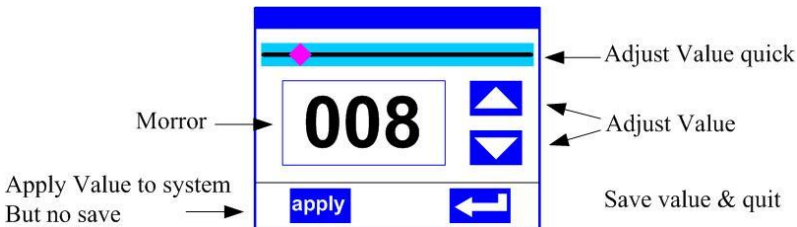

Figure 4 Dialog of value setting

**Modify value:** Can quickly modify value via pull the slider to the desired position, or click the button of 'up' or 'down' whit finger on the right side to set the exact desired value, another way is roll encoder on the right hand side of panel.

**Apply value:** When Value had been modified, Then press the bottom of 'apply' in the left corner to apply to the light, but hav't saved;

**Save Value:** Any time, click on the lower right corner of the "OK" button, the setting will been saved into internal memory.

### 3. Boolean parameter setting

when the selected parameters is a Boolean value (such as ON or OFF), can directly modify setting by chick corresponding item, the setting will been saved right now. When the parameter is a key item, chick corresponding item, will been popup ask for the confirm. Chick 'sure' to confirm.

### 4. Sub Menu (Parameter)

Chick item of main menu, enter corresponding sub menu, \ total 6 sub menu, includes class of parameter and status:

**ADDRESS:** Set light DMX address.

**WORKMOD:** Set light work mode, master or slave mode when in auto run mode.

**DISPLAY:** Set display parameter, eg. select language.

**TEST:** Used for test light, modify DMX channel data to test function, the corresponding function of reference channel function table.

**ADVANCE:** Set light running parameter.

**STATUS:** view light current status.

### 3. Operation and parameter instruction

Via following operation, enter sub menu (parameter menu)

- In main menu, chick 1/6 function button into corresponding parameter menu.
- In sub menu (page), chick main item on the left side of displayer, can shift to corresponding sub menu(page) quickly.

#### 1. Set DMX Address

Click and select the "ADDR", can enter the page of DMX address setting, range from 1 to 512, the address code shouldn't is not greater than (512- channels quantity), otherwise the light will not been controlled. Following is the operation:

Enter the page of DMX address, as shown in Figure 7, click the blank area in right side of display will pop-up dig log, modify value, then click 'ENTER' to confirm and save DMX address code.

#### 2. Set Light work mode

Enter the page of 'WORK MOD' and modify setting. Can set light work mode, control lamp and DMX channel mode..

Light includes 3 work mode: DMX MODE, AUTO RUN and SOUND MODE, Parameter definition as following:

**DMX Mode:** Under this mode, the light receive data from the DMX controller and move.

**AUTO RUN:** Under this mode, light will run with inside code(data), ignore data from DMX controller.

**SOUND Ctrl:** Under this mode, light ignore data from DMX controller., When there is a strong sound in stage, the light will run a scene, otherwise it will keep the last scene.

**M/S Choose:** 'M/S Choose' is available when light just in 'AUTO RUN' or 'SOUND Ctrl' mode. If this item is set as 'OFF', the light don't send data to other light via DMX Cable. When 'ON', the data will send to other slave light immediately.

**Lamp control:** Turn on lamp when this item is set 'ON', otherwise, turn off lamp. The gap between operation is limited to 30 second.

**Channel mode:** Light support 2 DMX Channel mode: sample or extend.

#### 3. Set display

Light support 2 language, rotation display:

**Language:** Select display as simplified Chinese or English.

**Screen Saver:** when panel is idle(these is no operation in 10 second), displayer will enter saver status. When set as 'mode 1', saver status is close display, as

'mode 2' saver status will display DMX address code(DMX MODE) or display LOGO(AUTO RUN or SOUND CTRL). As 'OFF', keep light up displayer and show main menu。

**Screen Rotation:** rotate displayer.

**Touch enable:** Disable or enable touch function, when disable, use encoder to operate light and set parameter.

**Touch adjust:** adjust touch function, normally, not enter this item.

Figure9 page of display

#### 4. Test light

Light will into test mode, in this mode, the light does not receive the data for DMX controller.:

PAN: range for 0 to 255;

TILT: range for 0 to 255;

FOCUS: range for 0 to 255;

COLOR: range for 0 to 255;

GOBO: range for 0 to 255;

PRISM: range for 0 to 255;

FROST: range for 0 to 255;;

STROBE: range for 0 to 255;。

#### 5. Set light run parameter

set the parameter of light:

Pan Invert: Reverse PAN move.

Tilt Invert: Reverse TILT mover.

Rectify enable: set as 'OFF', PAN or TILT will disable position rectify function. As 'ON', when PAN or TILT lose steps, light will rectify auto.

Pan Offset: Set PAN original position.

Tilt Offset: Set TILT original position.

Lamp up when: Select lamp on mode, includes 3 mode: power on, after reset done and manual;

Factory setting: restore all parameter to factory setting.

Figure 11 page of run parameter

#### 6. View status

Enter the page as shown in Figure 12:

View light current status, version;

DMXClr: Click to clear all DMX data to '0'.

SysRst: Click to reset light.

## Chapter 3 Channel description

### 1. Channel table

CHANNEL	NAME	VALUE	FUNCTION
CH 1	COLOR	0~4	WHITE
		5~9	WHITE +COLOR1
		10~14	COLOR1
		15~19	COLOR1 + COLOR2
		20~24	COLOR2
		25~29	COLOR2 + COLOR3
		30~34	COLOR3
		35~39	COLOR3 + COLOR4
		40~44	COLOR4
		45~49	COLOR4 + COLOR5
		50~54	COLOR5
		55~59	COLOR5 + COLOR6
		60~64	COLOR6
		65~69	COLOR6 + COLOR7

		70~74	COLOR7
		75~79	COLOR7 + COLOR8
		80~84	COLOR8
		85~89	COLOR8 + COLOR9
		90~94	COLOR9
		95~99	COLOR9 + COLOR10
		100~104	COLOR10
		105~109	COLOR10 + COLOR11
		110~114	COLOR11
		115~119	COLOR11 + COLOR12
		120~124	COLOR12
		125~129	COLOR12 + COLOR13
		130~134	COLOR13
		135~139	COLOR13 + COLOR14
		140~144	COLOR14
		145~149	COLOR14 + 白光
		150~199	Rotate forward (Fast -- slow)
		200~255	Rotate reverse (Slow -- fast)
CH 2	STROBE	0~3	Dark
		4~103	Slow strobe to fast strobe
		104~107	White
		108~207	Slow strobe to fast strobe
		208~212	white
		213~225	Free strobe ,slow
		226~238	Free strobe ,middle
		239~251	Free strobe ,fast
		252~255	White
CH 3	DIMMING	0~255	0 ~ 100% DIMMING
CH 4	Gobo	0~4	WHITE
		5~9	Gobo 1
		10~14	Gobo 2
		15~19	Gobo 3
		20~24	Gobo 4
		25~29	Gobo 5
		30~34	Gobo 6
		35~39	Gobo 7
		40~44	Gobo 8
		45~49	Gobo 9
		50~54	Gobo 10
		55~59	Gobo 11
		60~64	Gobo 12
		65~69	Gobo 13
		70~74	Gobo 14
		75~79	Gobo 15
80~84	Gobo 16		

		85~89	Gobo 17
		90~129	Rotate forward (Fast -- slow)
		130~134	stop (white)
		135~169	Rotate
		170~174	Gobo1,shaking
		175~179	Gobo2,shaking
		180~184	Gobo3,shaking
		185~189	Gobo4,shaking
		190~194	Gobo5,shaking
		195~199	Gobo6,shaking
		200~204	Gobo7,shaking
		205~209	Gobo8,shaking
		210~214	Gobo9,shaking
		215~219	Gobo10,shaking
		220~224	Gobo11,shaking
		225~229	Gobo12,shaking
		230~234	Gobo13,shaking
		235~239	Gobo14,shaking
		240~244	Gobo15,shaking
		245~249	Gobo16,shaking
		250~255	Gobo17,shaking
CH 5	PRISM	0~127	White
		128~255	Insert prism
CH 6	ROTATE PRISM	0~127	Angle 0~400
		128~191	Rotate forward (Fast --slow)
		192~255	Rotate reverse (Slow -- fast)
CH 7			/
CH 8	FROST	0~255	Insert frost 0~100%
CH 9	FOCUS	0~255	From far to near
CH 10	PAN	0~255	0~540°
CH 11	PAN FINE	0~255	
CH 12	TILT	0~255	0~270°
CH 13	TILT FINE	0~255	
CH 14	P/T SPEED	0~255	Fast to slow
CH 15	RESET	0~127	none
		128~200	Reset light (stay over 3 second)
		201~255	none
CH 16	LAMP	0~9	none
		10~100	Turn on lamp (stay over 3 second)
		101~255	Turn off lamp (stay over 3 second)